



BH-4A

Portable Multi Gas Detector

 SIL  FC RoHS CE

Technical Parameters

Alarm method:	sound/light/vibration	Sensor life:	2 years
Response time:	T ₉₀ <60s	Display:	2.0 inch LCD display
Charging time:	4~6 hours	Explosion-proof level:	IP65
Working time:	≤8 hours	Product Size:	130*67*30mm
Working environment:	-10°C~50°C,<95%RH	Weight:	200g

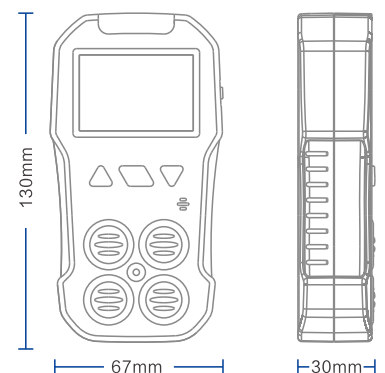

BH-4A Portable Multi Gas Detector



BH-4A, using 2.0 inch industrial level LCD display, adopts imported gas sensor and microprocessor technology, fast response, high sensitivity, performance stable and good repeatability, small in size, easier to carry and operate, these all makes it very popular in the market.

It is widely used in the area where explosion-proof is required or toxic gas leaks, like underground channels or mining industry, so as to protect workers' life and avoid damage on the relevant equipment.

Alarm methods

Indicate alarm by sound, light and vibration. User can set high low alarm point according to actual need.

Large capacity battery

Fast charging, can work continuously for at least 8 hours. Packing with Aluminum alloy box, convenient to carry.

Product Features

- Industrial sensor
- Respond quickly
- Sound light and vibration the three alarm methods
- large capacity battery
- Three-defense design
- Cost-effective



Support sensor

Support more than 30 types of sensors, free combinations and flexible configurations as needed
 Combustible gas (EX) oxygen (O₂) hydrogen sulfide (H₂S) carbon oxide (CO)

Default range

(Customized according to requirements)

EX: 0~100%LEL
 O₂: 0~30%VOL
 H₂S: 0~100PPM
 CO: 0~1000PPM

Resolution

EX: 1%LEL
 O₂: 0.1%VOL
 H₂S: 1PPM
 CO: 1PPM



+86 371-86533226

sales@bosean.com

Block 10, Yida New Park No. 16 JinZhan Road, High-Tech zone, Zhengzhou, Henan Province.