



BH-90A

Portable Single Gas Detector

SIL FC RoHS CE MC PA

Technical Parameters

Alarm type:	sound, light, vibration	Sampling method:	Natural Diffusion
T₉₀:	<60s	T&H:	-10°C ~ 50°C, <95%RH
Operating time:	4~6 hours	Sensor life:	2 years
Working time:	≲ 10 hours	Display:	1.77 inch LCD display
Dimensions:	109 × 60 × 30mm 130g	Precision level:	IP65

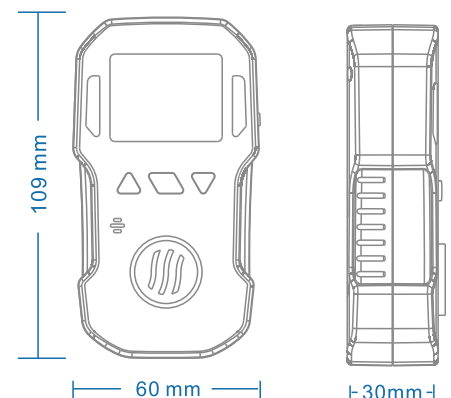

BH-90A Portable Single Gas Detector

BH-90A is an economical single gas detector, adopting advanced sensor and micro control technical, quick response, high accuracy, great steadily and repeatability, the detector's performance is the leader grade in the industry, easy to operate.

The detector has built in large and rechargeable lithium battery, long standby; adopt LCD screen that can indicate every technical data and gas concentration value perfectly. The shell is designed by anti slip material, small and portable. Suitable for explosion proof, toxic gas leak rescue, underground pipe, mine, metallurgy ,electric industry, chemical, tunnel and other places. prevent the accident efficiently, keep the worker safe and prevent the facilities from being destroyed.



Industrial sensor



Three alarm methods



Large capacity battery



Cost-effective



Fast response



Anti-fire,water, dust

Sensors supported

Detect more than 30 kinds of gas. Can customize flexibly according to users' needs.

Some common gases:

EX , O₂ , H₂S ,CO ,H₂ ,NO ,NO₂ ,SO₂ ,O₃ ,NH₃ ,Cl₂

Range

EX: 0~100%LEL

O₂: 0~30%VOL

H₂S: 0~100PPM

CO: 0~1000PPM

Resolution

EX: 1%LEL

O₂: 0.1%VOL

H₂S: 1PPM

CO: 1PPM

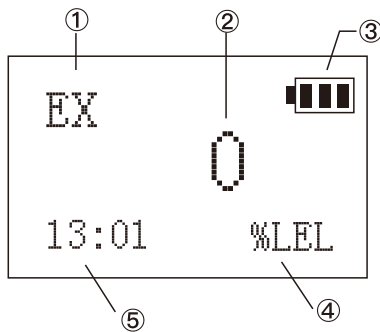

1. Gas display
2. Gas concentration content display
3. Battery power display
4. Unit power display
5. Time display

