



BH-90E

Portable Combustible
Gas Leak Detector

SIL  FC RoHS CE

Technical Parameters

Alarm method:	sound/light/vibration
Sensor life:	2 years
Charging time:	6h~8h
Working time:	more than 8h
Working environment:	Tem:-10°C~50°C; Hum:≤95%RH no dew
Response time:	T ₉₀ <60s
Power:	Rechargeable Li battery DC3.7V

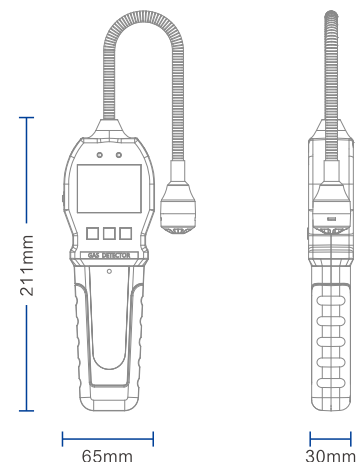



BH-90E Gas Leak Detector

BH-90E portable gas detector (hereinafter called detector) is a new type of detector for detecting gas leakage from the gas pipelines, gas valve, and other possible places. With imported high quality semi-conductor sensor and embedded microcontroller, it has very high sensitivity, excellent man-machine operation interface and various adaptive ability.

The housing of the detector is made of high strength engineering plastics and compound anti-slip rubber. It is waterproof, dustproof, and with good handle.

Product Features

- ① Extension flexible probe
- ② Sound light vibration and display the four alarm methods
- ③ Three - defense design
- ④ High quality material
- ⑤ large capacity battery
- ⑥ High efficiency



Technical Data

Detection range: 0-10000 $\mu\text{mol/mol}$ **Resolution:** 1 $\mu\text{mol/mol}$ **Applicable gas:** Combustible gas

Alarm point: Can be set, the normal low alarm point is 500 $\mu\text{mol/mol}$. High alarm point is 2000 $\mu\text{mol/mol}$.

Alarm: LCD indication, audible, visual and vibration alert alarm, and low voltage alarm.

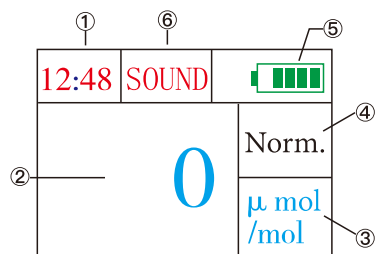

- 1. Time
- 2. Concentration value
- 3. Unit
- 4. Status
- 5. Battery
- 6. Sound



+86 371-86533226 sales@bosean.com
 Block 10, Yida New Park No. 16 JinZhan Road, High-Tech zone, Zhengzhou, Henan Province.