



K-600

Gas Detector with Built in Pump

【Single or Multi】

 Exib IIC T4 Gb

SIL FC RoHS CE   

Technical Parameters

Alarm type:	sound, light, vibration curve display	Sampling method:	Pumping
T₉₀:	<60s	T&H:	-20°C ~ 50°C, <95%RH
Operating time:	4~6 hours	Sensor life:	2 years
Working time:	≲ 10 hours	Display:	2.4 inch LCD display
Dimensions:	174 × 68 × 47mm 400g	Precision level:	IP65

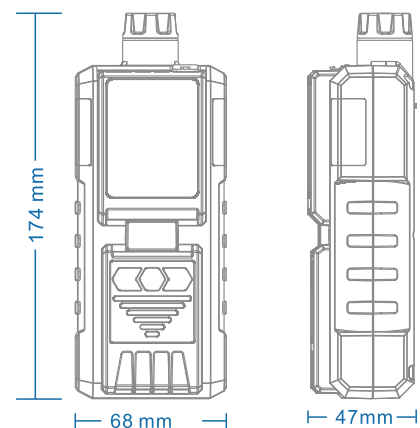

Size: 174x68x47mm

K-600 Gas detector with Built in Pump (Single or Multi)

K-600 portable multi-gas detector with built-in pump is a new intelligent gas detector, which adopts an advanced integrated circuit, with standard intelligent level design technology, and proprietary digital analog hybrid communication technology. The detector is of excellent sensitivity and repeatability, which makes it very easy to use and maintain. Thus greatly meets the safety requirements of industrial sites with high reliability. The detector is made of high-strength engineering plastics, compound non-slip rubber, which is of high strength and good hand feeling. what's more, the detector is water-proof, dust-proof and explosion-proof.

It is widely used in petroleum, chemical, environmental, metallurgy, refining, gas transmission and distribution, biochemical medicine, agricultural and other industries.



Product Features

- Chinese- English switching
- Four alarm methods
- Expandable to five gases
- Curve value display
- Support PID gas sensor
- Support multiple gas unit switching



Technical Parameters

Gas	Range	LowAlarm	HighAlarm	Resolution
EX	0-100%LEL	20%LEL	50%LEL	1%LEL
H2S	0-100PPM	10PPM	35PPM	1PPM
CO	0-1000PPM	50PPM	150PPM	1PPM
O2	0-30%VOL	19.5%VOL	23.5%VOL	0.1%VOL



+86 371-86533226

sales@bosean.com

Block 10. Yida New Park No. 16 JinZhan Road, High-Tech zone, Zhengzhou, Henan Province.